

# Model aSENSE® - Alarm

## Carbon dioxide Alarm Unit for wall and duct mounting

### PRODUCT DESCRIPTION

#### *aSENSE® - Alarm*

is a microprocessor based alarm unit that measures both CO<sub>2</sub> concentration and temperature in the ambient air. In addition to the actual carbon dioxide value, the 8 hours TWA value is calculated and presented on the built-in LCD.

*aSENSE® - Alarm* is available for installation on the wall or in a ventilation duct. It is a very flexible alarm unit with programmable outputs for linear control of fans or peripheral alarm equipment.



*aSENSE® Alarm*  
(wall mount IP 54)



*aSENSE® Alarm-K*  
(duct mount IP 65)

### FEATURES

- state-of-the-art Non-Dispersive InfraRed (NDIR) technology to measure the carbon dioxide (CO<sub>2</sub>) concentration
- calculates the 8 hours TWA CO<sub>2</sub> value.
- complementary temperature sensor.
- built-in LCD presents the actual carbon dioxide and temperature values as well as the calculated 8 hrs. TWA CO<sub>2</sub> value.
- fully programmable control outputs.
- internal automatic self diagnostics
- maintenance interval > 5 years
- available in IP54 wall housing and IP65 duct housing.
- serial communication port for connection to PC, GSM-module or local network

### APPLICATIONS

*aSENSE® -Alarm* can be installed as a personal safety alarm unit wherever high concentration carbon dioxide is produced, stored, generated and/or used, e.g. in:

- pubs, restaurants, wine/beer cellars
- breweries, distilleries, wineries
- purifying plants
- packing industry
- slaughter houses

Any carbon dioxide leakage may deplete the air from oxygen and the need for reliable alarm systems is obvious. A number of deaths occur each year in such unfortunate accidents. *aSENSE® -Alarm* is especially developed to work as an alarm unit in spaces where the climate or the working environment needs to be supervised.

### CONNECTIONS

#### Screw terminal

1	G+	12 VDC or 24VAC/VDC
2	G0	system ground
3	OUT1	control signal (+)<5V /10V or 20mA
4	OUT2	control signal (+)<5V /10V or 20mA
5	M	signal ground
6,	OUT3	ON/OFF relay
7		
8	OUT4	control signal (+)<5V /10V or open collector

#### Extra terminal:

9,10	DI1	switch input delay timer & regulations
------	-----	--

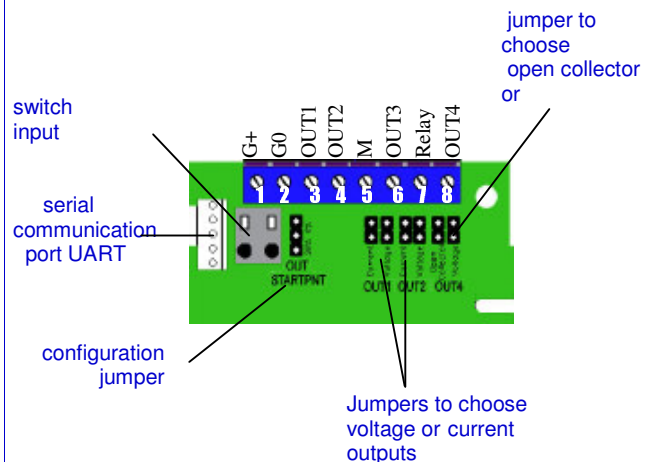

# aSENSE<sup>®</sup> - Alarm technical specification

## General Performance

Compliance with .....	EMC directive 89/336/EEC
Operating Temperature Range <sup>1</sup> .....	0 to + 50 °C
Storage Temperature Range .....	-20 to +70 °C
Operating Humidity Range .....	0 to 95% RH (non-condensing)
Warm-up Time .....	≤ 1 min. (@ full specs ≤ 15 minutes)
Sensor Life Expectancy .....	> 15 years
Maintenance Interval .....	no maintenance required <sup>2,3</sup>
Self Diagnostics .....	complete function check of the sensor
Status LED Indicators .....	yellow = maintenance support, red = relay closed, red = open collector conductive
Display .....	4 Digits, 7 segments LCD with ppm / °C / % indicator
Pushbuttons <sup>4</sup> .....	offer a selection of installation support, calibration and operation functions

## Electrical/Mechanical

Power Input .....	24 VAC/VDC±20%, 50-60 Hz (half-wave rectifier input), (12 VDC optional)
Power Consumption .....	≤ 3 Watts average
Wiring Connections .....	max 1,5 mm <sup>2</sup> wires
Main terminal block .....	screw terminals
Digital/Analog inputs block .....	spring load terminals
UART connector .....	5-pin, 2.54 mm pitch, slide connector
Dimensions without housing .....	9.7 x 6.1 x 1.9 cm (L x W x D)

## Outputs

Analog <sup>5</sup>	
Protection .....	PTC fuse (auto reset) on signal return M, short-circuit safe
Output limits .....	MIN & MAX limits may be individually set to all outputs
Linear outputs / OUT1 & OUT2 .....	0/2-10 VDC R <sub>OUT</sub> < 100 OHM, R <sub>load</sub> > 5k OHM (0/1-5 VDC optional) 0/4-20 mA R <sub>load</sub> < 500 OHM
Linear output / OUT4 .....	0-10 VDC R <sub>OUT</sub> < 100 OHM, R <sub>load</sub> > 5k OHM
D/A Resolution .....	10 bits, 10 mV / 0.016 mA
D/A Conversion Accuracy .....	voltage mode: ± 2% of reading ± 50 mV / current loop : ± 2% of reading ± 0.3 mA
ON/OFF	
Relay / OUT3 .....	isolated N.O., 1mA/5V up to 1A/50VAC/24VDC.
Open collector / OUT4 .....	in ON/OFF mode: max 0.5A/55VDC (halfwave rectifier for AC)
UART Serial com port	
Protocol .....	SenseAir protocol (see <i>comprot 0700xx rev 3_04.pdf</i> ) <sup>6</sup>
PC-interface .....	RS232 UART cable with sliding contact and driver (model A232 Cable)
PC User Interface Program .....	UIP version 4.0 (or higher) <sup>7</sup>
RS485 network com. ....	(accessory -485) RS485 terminal slide-on port, network capabilities up to 30 units
LonWorks™ network com. ....	(accessory -LON) LonWorks™ add-on PCB

## CO<sub>2</sub> Measurement

Operating Principle .....	Non-dispersive infrared (NDIR) with Automatic Baseline Correction (ABC) <sup>7</sup>
Gas Sampling Mode .....	diffusion
Response Time (T <sub>1/e</sub> ) .....	2 min. diffusion time (20 sec. with tube connection at 0.1 litre/minute gas flow)
Accuracy <sup>8</sup> .....	± 1% of measurement range ± 5 % of measured value
Pressure Dependence .....	+ 1.58 % reading per kPa deviation from normal pressure, 100 kPa
Annual Zero Drift <sup>9</sup> .....	< ±0.3 % of measurement range
Measurement range .....	0 - 3 % <sub>vol.</sub>

## Temperature Measurement

Operating Principle .....	Thermistor
Measurement Range .....	-20 to +60 °C
Accuracy .....	± 0.5 °C
Digital Resolution .....	0.1 °C (0.01 °C via UART)

## O<sub>2</sub> Measurement (model options - O<sub>2</sub>)

Measurement principle .....	electro-chemical diffusion cell with automatic span calibration (ABC) <sup>7</sup>
Response Time (1/e) .....	< 2 min. diffusion time
Measurement range .....	0 - 35 % <sub>vol.</sub> O <sub>2</sub>
Accuracy <sup>9</sup> .....	± 5 % of measured value
Sensor Life Time .....	2-5 years <sup>10</sup>

Note 1: Lower temp. operation range can be reached with a box heater assembly.

Note 2: In normal IAQ applications.

Note 3: The oxygen electro-chemical cell may have to be replaced every 2-5 years.

Note 4: Different menus exist for different models/applications.

Note 5: Specs are valid for output load connected to G0 or common signal return M.

Note 6: Free download from SenseAir's home page [www.senseair.com](http://www.senseair.com)

Note 7: The ABC function implies maintenance free operation. For CO<sub>2</sub> sensors, ABC automatically corrects any possible zero drift. For O<sub>2</sub> sensors, ABC automatically corrects any span drift in common electro-chemical cells.

Note 8: Accuracy is defined after 3 weeks continuous operation in normal conditions

Note 9: In normal IAQ applications.

Note 10: Nominal sensor life is 1 000 000 %O<sub>2</sub> hours at 25 °C and 50%RH, but this will be reduced by increased temperatures, as well as in dry air conditions.



Address: Box 96, SE-82060 Delsbo, SWEDEN  
Phone: +46-(0)653-71 77 70 • Fax: +46-(0)653-71 77 89  
E-mail: [senseair@senseair.se](mailto:senseair@senseair.se) • Homepage: [www.senseair.com](http://www.senseair.com)

Jan '04

